

CS4 / CS-L

APPARATUSES FOR MEASURING TEMPERATURE VARIATIONS
OF MAGNETIC SUSCEPTIBILITY



User Manual

Version 2.0.3
September 2022

AGICO 

Contents

1	CS4/CS-L Introduction	1
1.1	CS4 Description	1
1.2	CS-L Description	1
1.3	Technical Specifications	2
1.4	Parts of CS4 system	3
1.4.1	Furnace	3
1.4.2	Temperature Control Unit	4
1.4.3	Laboratory Power Supply	4
1.4.4	Temperature Sensor	4
1.4.5	Measuring Vessel	5
1.4.6	Argon Gas	6
1.4.7	Cooling Circuit	7
1.5	Parts of CS-L system	8
1.5.1	Cryostat	8
1.5.2	Liquid Nitrogen and Accessories	8
2	Installation Procedures	9
2.1	Choosing the Place	9
2.2	Interconnection of Units	10
3	Measurements	12
3.1	Specimen Handling	12
3.2	Measurements in the Low Temperature Mode	14
3.3	Measurements in High Temperature Mode	15
4	Troubleshooting	16
4.1	Hardware Indicators	16
4.2	Software Error Messages	17
4.3	Fuses	17
4.4	Bad Cooling	18
4.5	Temperature Sensor Testing	19
4.6	Furnace Testing	20
5	Maintenance	21
5.1	Cleaning the Temperature Sensor and Measuring Vessel	21
5.1.1	Measuring Vessel Cleaning	21
5.1.2	Temperature Sensor Cleaning	21

6 Appendix	22
6.1 EC Declaration of Conformity	22
6.2 Warranty	23

User Manual Conventions

 **Prohibition** symbol is used to prohibit any action which may cause a loss of properties, damage or injury.









 **Warning** symbol is used to draw a special attention to an important information.











 **Information** symbol is used to give a useful hint or tip for more comfortable work with the instrument.

General Safety Instructions

Before beginning of work with the instrument, review the following safety precautions to avoid injury and prevent damage to this product or any products connected to it.

Service procedures should be performed by qualified personnel only!

-  **Do Not Operate Without Covers!** To avoid electric shock or fire hazard, do not operate this product with covers or panels removed.
-  **Do Not Operate in Wet or Damp Conditions!** To avoid electric shock, do not operate this product in wet or damp conditions.
-  **Do Not Operate in an Explosive Atmosphere!** To avoid injury or fire hazard, do not operate this product in an explosive atmosphere.
-  **Do Not Disconnect Connectors!** To avoid damage of the instrument never disconnect any connector while the device is ON.
-  **Do Not Operate With Suspected Failures!** If you suspect there is damage to this product, have it inspected by qualified service personnel.
-  **Ground The Instrument!** The instrument is grounded through the Protective Earth lead of the power cord. To avoid electric shock, it is essential to connect the earth terminal of power cord to the Protective Earth terminal before any inputs or outputs.
-  **Do Not Insert Anything into the Holes of Fan!** Do not insert anything into the holes of the fan to avoid damaging the instrument.
-  **Use Proper Power Cord!** To avoid fire hazard, use only the power cord specified for this product.
-  **Fasten Connectors!** Do not operate the instrument if all connectors are not properly plugged and fixed by screws.

-  **Use Proper Mains Voltage!** Do not operate this product from a power source that is outside of the specified voltage range.
 -  **Use Proper Fuses Only!** Do not use fuses which are not specified by the manufacturer. If a fuse with a different characteristics or value is used, the protection is not effective.
 -  **Operator's Training!** Operator should be familiar with operation of the instrument and Safety Regulations.
 -  **Use Manufacturer's Cables Only!** Other devices can be connected to the instrument via the appropriate cables only.
 -  **Do not drop the product and do not expose it to any major shocks!**
 -  **Do not operate the product outside the power limits given in the specifications!**
 -  **Keep the packaging material out of the reach of children to prevent the risk of suffocation!**
 -  **The first installation and customer training is performed exclusively by the AGICO technician or by the authorized representative.**
-  Unstable or highly disturbed AC power may invoke safety circuits to protect the sensitive electronic parts by switching OFF the instrument or burning inner fuses.
-  **Dispose of packaging material immediately according to locally applicable regulations!**

Storage and Transportation

The properly wrapped instrument can be stored and transported at a temperature -20 °C to + 55 °C and relative humidity up to 80 %. The instrument must be stored at suitable place, free of dust and chemical evaporation. **Handle with extreme care! Some parts are very fragile.**

1 CS4/CS-L Introduction

The **CS4** and **CSL** (High/Low Temperature Apparatuses) have been designed as an accessory for Kappabridges **MFK2-FA**, **MFK1-FA/A** or **KLY5-A** to enable measurements of the temperature variation of magnetic susceptibility.

1.1 CS4 Description

The **CS4 High Temperature Furnace Apparatus** is used for the measurement of the temperature variation of low-field magnetic susceptibility of minerals, rocks and synthetic materials in the temperature range from ambient temperature to 700 °C.

The apparatus consists of non-magnetic furnace with a special platinum thermometer, CS4 temperature control unit, laboratory power supply EA-PS, cooling water reservoir with pump, and argon flow meter. The specimen is placed in a measuring vessel which is heated by a platinum wire in three selectable heating rates. The temperature of the specimen is measured by a special platinum thermometer. The protective argon atmosphere can be applied during the heating to prevent the oxidation of the measured specimen. In order to perform the susceptibility measurement at a chosen temperature range, the instrument moves automatically the furnace into and out of the pick-up coil of the Kappabridge. The quasi-continuous measurement process is fully automated, being controlled by the software.

1.2 CS-L Description

The **CS-L Low Temperature Cryostat Apparatus** is used for the measurement of the temperature variation of low-field magnetic susceptibility of minerals, rocks and synthetic materials in the temperature range from minus 192 °C to ambient temperature.

The apparatus consists of the non-magnetic cryostat with a special platinum thermometer, CS4 temperature control unit and laboratory power supply EA-PS. The specimen is placed in a measuring vessel which is cooled inside the cryostat by liquid nitrogen and then heated spontaneously to a given temperature. The argon gas is used for depleting the liquid nitrogen out of the cryostat. Temperature of the specimen is measured by the platinum thermometer. The quasi-continuous measurement process, after cooling the specimen, is fully automated, being controlled by the software.

1.3 Technical Specifications

- Maximum specimen volume (fragments or powder) – 0.25 cm³
- Inner diameter of measuring vessel – 6.5 mm
- Sensitivity to susceptibility changes (976 Hz, 400 Am⁻¹) – 1×10^{-7} SI
- Temperature range CS4 – ambient temperature to 700 °C
- Temperature range CS-L – -192 °C to ambient temperature
- Accuracy of temperature sensor – ± 2 °C, see also IEC 751 - Pt100
- Argon gas flow requirement (protective atmosphere) –approx. 100 ml per minute
- Amount of liquid nitrogen (cooling cryostat) –approx. 0.25 l for one cooling
- Power requirements – 240, 230, 120, 100 V ± 10 %, 50/60 Hz
- Power consumption – 350 VA

Dimensions / Mass

- Temperature control unit – 230 mm × 190 mm × 130 mm, 1.7 kg
- Laboratory power supply EA-PS –310 mm × 240 mm × 130 mm, 8 kg
- Water container with Pump –380 mm × 380 mm × 700 mm, 2 kg (without water)
- Argon flow meter – 32 mm × 32 mm × 140 mm, 1 kg
- Furnace/Cryostat – dia. 60 mm, length 220 mm, 0.5 kg

1.4 Parts of CS4 system

1.4.1 Furnace

Special non-magnetic furnace is utilized to heat-up the powdered specimen up to 700 °C. Cross-section of the furnace is on the Fig.1. It consists of these parts:

- Plastic outer tube
- Space for cooling water
- Outer silica glass tube
- Alumina (Al_2O_3) powder filler
- Inner silica glass tube with heating platinum wires (bifilar winding) and with space for measuring vessel

The power for heating of the furnace is connected through two wire cables fixed with two screws. Cooling water is connected through pair of silicon tubes.

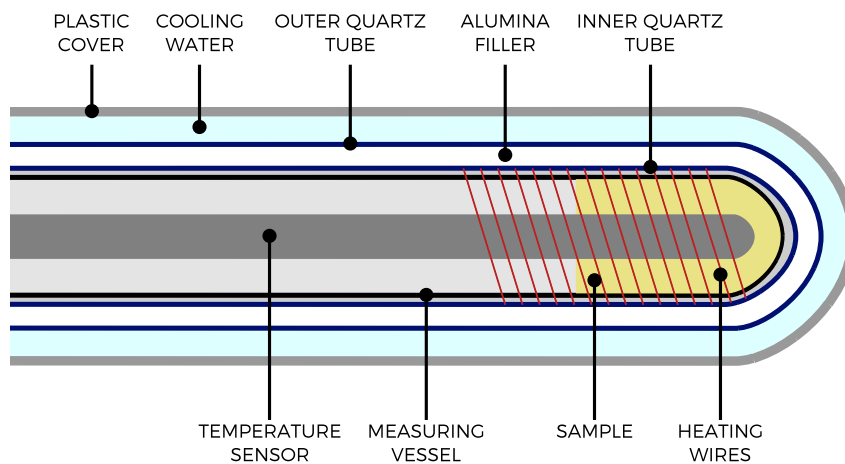

Figure 1: Furnace cross-section.

1.4.2 Temperature Control Unit

Temperature Control Unit is common for both CS4 and CS-L apparatuses. It controls the entire heating and cooling process, checks current status of the measurement (temperature, heating power, cooling water flow) and communicates with the Kappabridge. CS4 is activated automatically by the Kappabridge after the activation command from software. Correct interconnection between the Kappabridge and CS4 is indicated by the blinking green light on the front panel of the Temperature Control Unit. Activated CS4 is indicated by the continuous green light in same location. Back panel of the Temperature Control Unit is shown on Fig. 2.

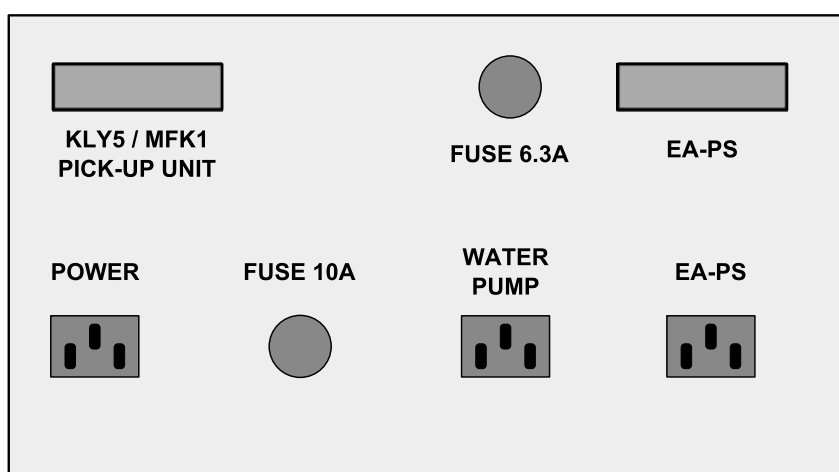

Figure 2: Back panel of CS4 Temperature Control Unit

1.4.3 Laboratory Power Supply

Laboratory Power Supply is the source of the electric current for the heating wires of the furnace and cryostat. Voltage and current are controlled by the Temperature Control Unit. Actual values of the voltage and current are shown on the displays on the front side. Power Supply is automatically switched ON during the initialization of the apparatuses. Keep the main switch of the Power Supply ON all the time.

1.4.4 Temperature Sensor

Temperature sensor schematic view is shown on Fig 3. The measuring sensor itself is a special platinum element (Pt100) whose resistance is temperature dependent. The thermometer is connected to the system by 15-pin connector, the same as the one used for the rotator of the Kappabridges.

i Sensor is common for both high and low temperature measurements, but appropriate upper cap has to be used. **White** one is for the **low** temperature measurements, **black** is for the **high** temperature curves. It is recommended to close the inlet of argon gas with a little piece of rubber tube with knot at the end for low temperature measurements. It reduces the effect of presence of the highly paramagnetic liquid oxygen for temperatures below -183°C .

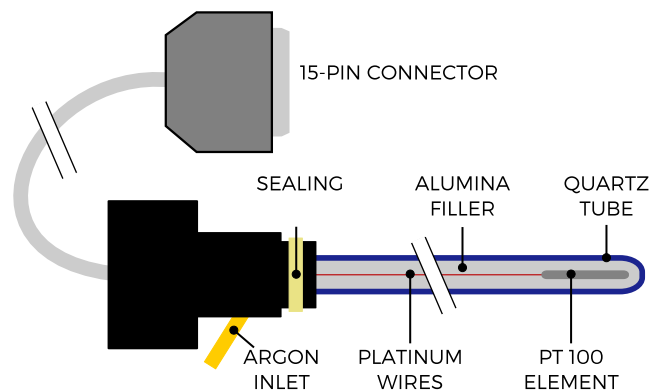

Figure 3: Temperature sensor schematic view.

1.4.5 Measuring Vessel

Measuring vessel is made of the quartz glass, inner diameter of the tube is approx. 6.5 mm. Volume of the specimen is approximately 0.25 cm^3 – this equals to the 20 mm height of the specimen with temperature sensor inserted into the measuring vessel.

1.4.6 Argon Gas

⚠ End user is required to prepare argon gas and appropriate reduction valve before the installation.

The protective Argon atmosphere can be optionally used to prevent the chemical changes of the specimen during the measurements of the high temperature variations of susceptibility using the **CS4** apparatus. Argon gas is also used to expel liquid nitrogen out of the cryostat, after proper cooling of the sample for the measurements of low temperature variations of magnetic susceptibility with **CS-L** apparatus.

Recommended purity of the argon gas is 99.5% or higher. Standard 40 liter bottle of argon gas can serve for several years of intensive measurements.

Flow meter, blowgun and all tubing are provided with the instrument.

It is necessary to have pressure reduction valve on the bottle with range of output pressures from 0 up to approx. 10 bars (150 psi). Inner diameter of the argon tubing is 8 mm (5/16 inch) so the counter-piece on the valve must be prepared for such tube. See picture 4.



Figure 4: Details of reduction valve for Argon gas, A - reduction valve, B - tube connection, inner diameter of tube is 8 mm (5/16 inch), C- detail of tube counter-piece

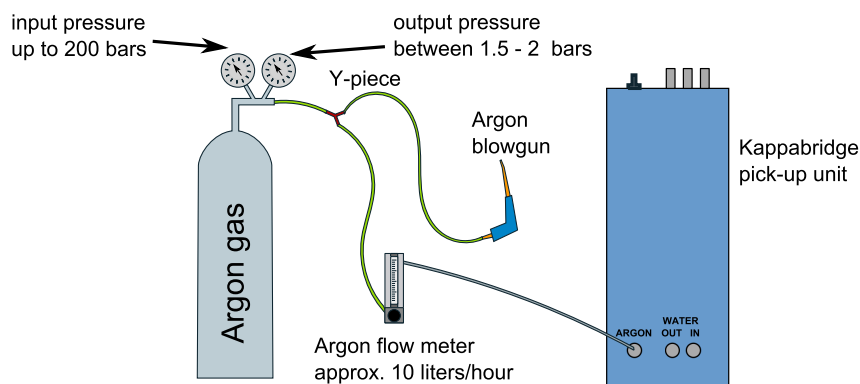

Figure 5: Argon gas connections

1.4.7 Cooling Circuit



End user is required to prepare 50 litres of distilled water before the installation.

The **CS4** apparatus is equipped with a closed water circuit for thermally shielding the pick-up coil of the Kappabridge from the hot furnace. The main parts of the cooling system are double mantle of the furnace, pipes, flow indicator and water container with the pump.

50 liters of distilled water is required for the cooling system. Distilled water is necessary for two main reasons:

- Absence of the magnetic particles which may affect the measurement.
- Distilled water is not favorable environment for bacteria or algae which may grow into the water.



Usual life-cycle of the water is one or two years. It is recommended to change the water every year. The life time of the water may be increased by the adding some kind of algaecide for water baths and circulators. In AGICO we are using neoLab-BAD Stabil, the dosage is 25 ml per year (for 50 liters reservoir). Some other kind can be used, but it must be chlorine free to prevent any damage of the cooling system.

Water Reservoir / Pick-up Unit Interconnection

- An outlet of the “warm” water (WATER-OUT) on the left side of the Pick-Up unit is connected by approx. 2.5 m long tubing with an inlet IN of the water container. Ends of the tube are marked by the **red color** as well as its respective counterparts.
- An inlet of the “cold” water (WATER-IN) of the PICK-UP unit left side is connected by approx. 2.5 m long tubing with an outlet OUT of the water container. Both ends of the tube are marked by the **blue color** as well as its respective counterparts.
- Proper **flow rate** of the water through the cooling circuit is **from 0.5 to 1.2 l/min**. It is constantly measured by the water flow meter and checked by Temperature Control Unit. If the flow rate is below 0.3 l/min instrument automatically switches OFF the heating of the furnace.

1.5 Parts of CS-L system

i Presence of the CS4 (or CS-3) system is mandatory for using of the CS-L system, since CS-L requires Temperature Control Unit, Laboratory Power Supply and Argon gas of the CS4 apparatus.

1.5.1 Cryostat

Special non-magnetic cryostat is utilized to cool down the powdered specimen to the temperature of $-192\text{ }^{\circ}\text{C}$. Cross-section of the cryostat is shown on the Fig. 6. It consists of these parts:

- Plastic outer tube
- Dewar vessel with heating wires on the outer surface
- Space for the liquid nitrogen
- Teflon (PTFE) thermal reservoir with space for the measuring vessel

Cryostat is connected to the Kappabridge through the 9-pin cannon connector. If the cryostat is connected the low temperature mode is automatically chosen by the data acquisition software.

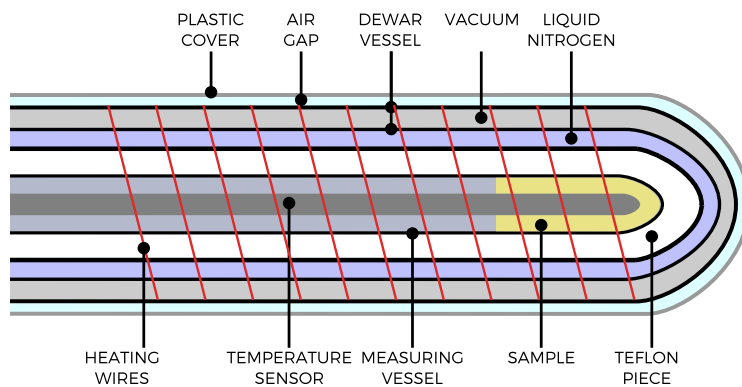



Figure 6: Cryostat cross-section.

1.5.2 Liquid Nitrogen and Accessories

Approx. amount of the liquid nitrogen is 0.25 liter per one low-temperature measurement. We recommend 10 liter Dewar bottle for storing of the liquid nitrogen. For further manipulation with smaller amounts of the liquid nitrogen polystyrene pot and special funnel are provided together with the CS-L instrument. Argon gas is needed as well, because it is used for the expelling of the liquid nitrogen from the cryostat.

2 Installation Procedures

 The first installation and customer training is performed exclusively by the AGICO technician or by the authorized representative. If you need later to reinstall the apparatus, due to moving the instrument to another place or any other reasons, be sure that the following conditions are met to achieve guaranteed parameters.

2.1 Choosing the Place

 The instrument must not be placed near sources of alternating magnetic field, e.g. big transformers, electric motors, power lines etc.

 Do not place the instrument near thermal and electrical sources and keep it away from direct sunshine. The pick-up unit must not be exposed to heat from the sun or from other sources, which would affect the precision of measurement.

 Do not place the pick-up coils of Kappabridge near the other instruments or computer monitors.

 Do not place the instrument in a draughty room. Air conditioning may sometimes cause higher thermal drift of coils, prevent the direct air flow.

 The temperature in the room should be stable as much as possible. The temperature variation in the room should not exceed 2°C per hour.

 Place the instrument and pick-up unit on a wooden table with good stability which has no iron part under the working desk.

 During the measurement prevent the motion of the magnetic objects (metal parts of chairs, doors, furniture, watches, rings, components of your clothes etc.)

 Fig. 7 shows recommended layout of KLY5 or MFK2/MFK1/CS4 apparatuses parts.

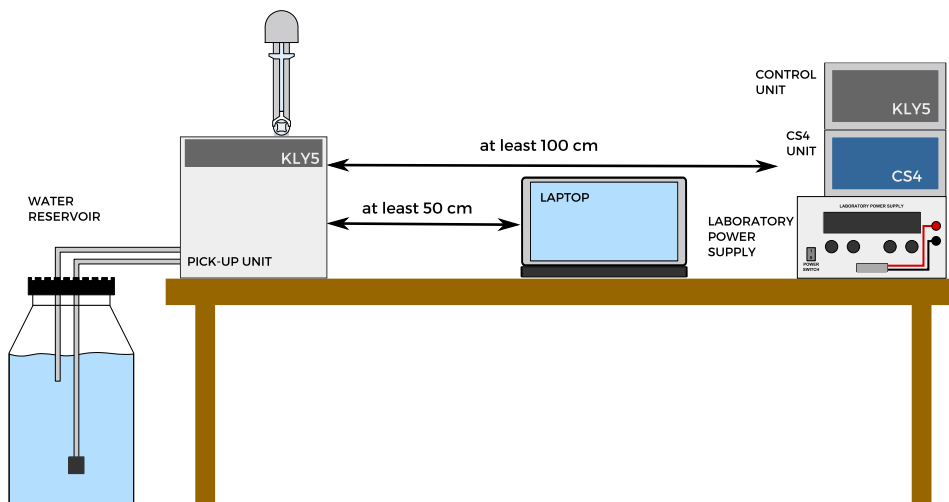

Figure 7: Recommended layout of KLY5 or MFK2/MFK1/CS4 apparatuses parts

2.2 Interconnection of Units

Fig.8 shows the Interconnection Scheme. **Be sure the instrument is unplugged from mains while connecting the cables. Do not manipulate with any connector while the instrument is ON.** Fix the connectors by screws, plug the mains socket and switch the Kappabridge on.

Check the cables for labels indicating the instrument sub-system to connect to (some cables may have same connectors on both sides, but different internal connections). Hoses of the cooling liquid are labeled with color marks at their end, as well as the connecting points on the barrel and pickup unit. Please check the correct hose connection, in some cases wrong connection can lead to the damage of the instrument.

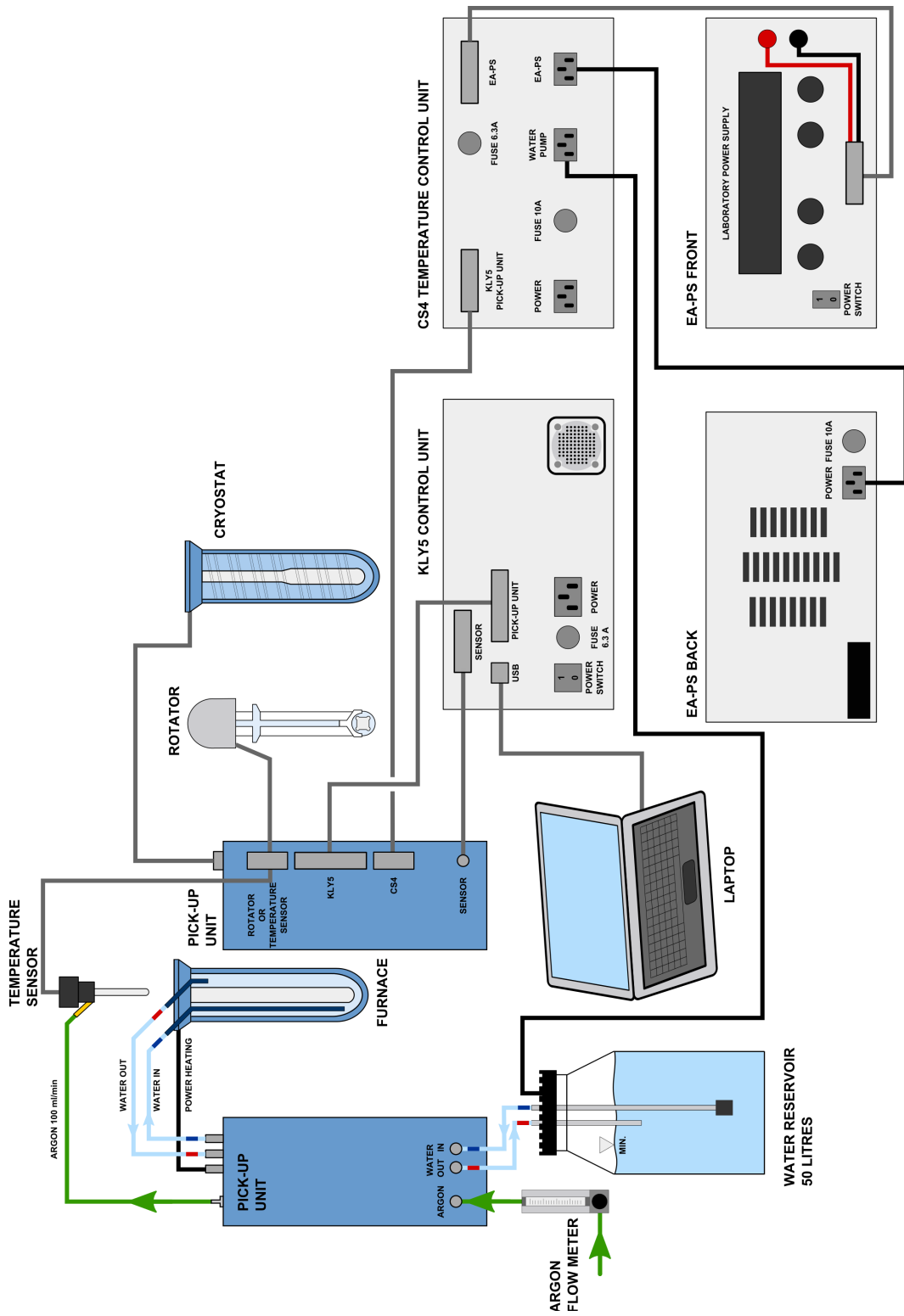

Figure 8: Interconnection Scheme of KLY5-A, MFK2-FA or MFK1-FA/A /CS4 /CS-L system

3 Measurements

3.1 Specimen Handling

- Prior to the connecting of the thermometer (or the rotator) be sure that the Kappabridge is switched OFF.
- The sensor and the silica glass pipe are very fragile. For this reason, a very careful manipulation is needed to prevent the damage of the pipe when it is inserted in or taken out from the measuring tube with the specimen. Fill the specimen to the measuring vessel, spread specimen in the horizontally along the vessel and carefully insert the thermometer. Then set the vessel with thermometer to the vertical position and shake gently the specimen down step by step as shown at Fig.9. Do not push the thermometer into the specimen which is on the bottom of the measuring vessel.

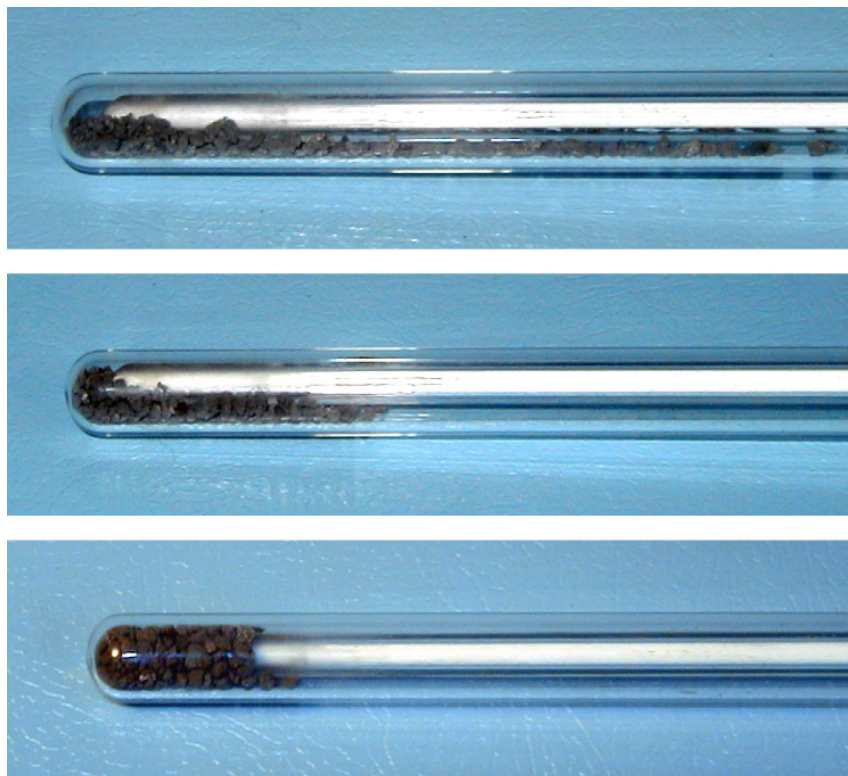



Figure 9: Insertion of the specimen into the measuring vessel-

- The basic type of a specimen measured is fine powder of a mineral or rock. Small fragments can also be used - in this case add Alumina (Al_2O_3) powder to

prevent position changes of the fragment(s) during the up and down movement. For the correct measurement, the specimen should be placed in the area of homogeneous temperature and homogeneous measuring magnetic field. This area extends at the length of **20 mm from the bottom of the specimen vessel**. The temperature sensor is placed in the center of this area. In this case, the measurement of a specimen temperature is the most precise and the measurement of the specimen susceptibility is the most sensitive.

- Temperature sensor should be carefully cleaned after each specimen measurement. For cleaning use cotton-wool, which can be soaked with various solvents (e.g. acetone, ethanol), if necessary. After cleaning dry up the sensor.
- Do not use ultrasonic cleaning for the thermometer. Take care of the outlet wires of the thermometer as well. In any manipulations, do not bend them too much.

 If the measurement in both modes (low and high temperature curve) is required, then begin with low temperature measurements. It will prevent non-reversible thermal changes to the specimen which may occur, if the specimen is exposed to high temperatures.

3.2 Measurements in the Low Temperature Mode

- Make sure that the Cryostat is connected to the Kappabridge Pick-Up Unit via. 9-pin cable.
- Make sure that the Temperature sensor is connected to the Kappabridge Pick-Up Unit via. 15-pin cable.
- Prepare your specimen as described in the section 3.1.
- Use the white upper cap to fix the specimen vessel – temperature sensor system.
- Use the argon blow gun to blow out the residual air from the inner part of the cryostat.
- Insert the measuring vessel with temperature sensor into the cryostat.
- Switch on the Kappabridge and run the data acquisition software.
- Initialize instrument and perform calibration if required.
- Check if the cryostat is properly mounted in the notch and if the tube for the output of the liquid nitrogen is not damaged.
- After opening a data file you will be prompted to fill the liquid nitrogen to cool the specimen down. Follow the flashing instructions of the software.
- Cover the measuring coil of the Kappabridge with sheet of paper to prevent the exposition of the coil to the liquid nitrogen. Even a small drop of LN₂ leads to the huge thermal drift of the coils which makes measurement impossible.
- Using the funnel fill **SLOWLY** the cryostat with liquid nitrogen up to the maximum allowed level. See Fig.10 for reference.
- Wait for the required temperature of the sample. LN₂ should be added if necessary. It usually takes about 5 minutes to cool down the sample.
- If the specimen is cooled down the software prompts to apply argon. Wait for the message **Apply Argon and Start Measurement**, cover the front hole by the tip of finger to increase the pressure of the argon inside the cryostat to achieve easier depleting of the cryostat and then apply argon gas, flow about 20 l/min for approx. 3 sec., wait a few seconds and apply argon once again, two or three times.
- Do not forget to remove the sheet of paper which covers the coil.

- Start the measurement using appropriate software command.

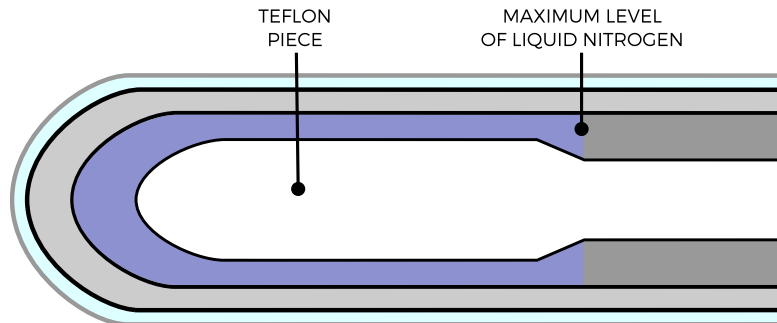

Figure 10: Maximal allowed level of the liquid nitrogen in the cryostat.

3.3 Measurements in High Temperature Mode

- Make sure that the Furnace is connected to the Kappabridge Pick-Up Unit, check the cooling water circuit.
- Make sure that the Temperature sensor is connected to the Kappabridge Pick-Up Unit via. 15-pin cable.
- Prepare your specimen as described in section 3.1.
- Use the black upper cap to fix the specimen vessel – temperature sensor system.
- Connect argon gas tube to the temperature sensor.
- Insert the measuring vessel with temperature sensor into the furnace.
- Switch on the Kappabridge and the data acquisition software.
- Initialize the instrument and perform calibration if required.
- Check if the furnace is properly mounted in the notch.
- Set the desired properties of the measurement such as the temperature range, heating rate and linger time.
- Start the measurement using the appropriate software command.

4 Troubleshooting

CS4/CS-L system contains plenty of hardware control circuits and software diagnostic tests to prevent any serious damage to the device. Some potential errors and their solution are noted below. Best way to solve the problems with AGICO devices, is to contact the manufacturer via. email address agico@agico.cz. Lifetime email support is free of cost, so do not hesitate to contact us with any questions.

4.1 Hardware Indicators

Temperature Control Unit Front Light

- **LED** blinking – Temperature Control Unit is properly connected to the Kappabridge, but currently inactive.
- **LED** continuous – Temperature Control Unit is properly connected to the Kappabridge and activated.
- **LED** still – Unspecified error. Actual error is displayed by the data acquisition software. See Tab.1 for more details.

Lights on the side of the Kappabridge Pick-Up Unit

- **LED** – intensity of the light indicates flow of the cooling water. Switches OFF if the water flow is below 0.3 l/min.
- **LED** – intensity of the light indicates heating current for the furnace.

4.2 Software Error Messages

Software error messages inform about the actual problems of the CS4/CS-L. Table 1 concludes recommended troubleshooting steps after some error occurs. These error messages are shown in the bottom status bar of the data acquisition software.

Error	Solution
CS Unit Missing	Kappabridge – CS4 connection cannot be established. Check all the interconnections according to the section 2.2. Check CS4 main fuse according to the section 4.3.
Bad Cooling	Water flow is too low. See the section 4.4 for more instructions.
No Voltage	Power Supply does not provide voltage for the heating wires. Check all the connections, check if the Laboratory Power Supply main switch is ON.
CS Open Heating	Power Supply provides the voltage, but the current is not detected. Check all the connections. Check the furnace according to the section 4.6.
Missing Temperature Sensor	Make sure that the temperature sensor is correctly connected. See the section 4.5 for more instructions.

Table 1: List of errors shown by data acquisition software

4.3 Fuses

Back panel of the Temperature Control Unit contains two fuses with ratings T10A / 250V and T6.3A / 250V. **T** stands for time lag (slow-burn) fuse, 10 A or 6.3 A indicates maximum current of fuses and 250 V indicates maximum voltage. See Fig. 2 for the reference.

If needed the main fuse can be easily replaced. Use the flat head screwdriver to unlock the socket, then pull out the socket. After replacing the fuse push in the socket and lock it with screwdriver.



Mains cord must be disconnected! The power switch of Kappabridge must be turned off and Power cord of the CS4 Temperature Control Unit must be disconnected during the fuse exchange.

4.4 Bad Cooling

Message error **BAD COOLING** can occur for several reasons, so it is good to start with the next steps:

- Check if the pump of the water circuit works correctly - unplug the cable which goes out of the water reservoir, connect a standard power cord and plug it directly to the wall socket.
- Make sure that the water tubing from the reservoir to the pick-up unit is not over-bended or squeezed.
- Make sure that the water tubes are properly connected.

If these easy steps still not help, please follow next instructions.

Water pump Sometimes there is a problem with the impeller inside the pump. You can hear some noise, so you can expect that the pump is working, but the impeller is not rotating. To check it follow the next steps:

- **Switch OFF the Kappabridge and unplug the power cable from the pump to avoid risk of an electric shock.** It is the cable which goes from the water reservoir to the CS4 unit.
- Open the water reservoir by loosening the top cap. Pull out the water pump from the reservoir and remove the plastic tube connected to the pump.
- Turn the water inlet 90 degrees to the right and then remove it, as it is shown in Fig 11. Then pull out the impeller.
- Check if the impeller has any broken part. If yes, you can easily fix the broken plastic part of the impeller with glue. If necessary, please contact Agico for a spare impeller.



Figure 11: Water pump

4.5 Temperature Sensor Testing

If you notice the messages **Missing or Temperature sensor error** or **Missing or Temperature sensor not connected**, follow the next steps:

- Make sure that the Kappabridge is OFF. Disconnect the suspicious thermometer from the Pick-Up Unit.
- Measure the resistivity on the connector of the thermometer with the multi-meter, as you can see in the Fig. 12.
- Resistivity between the pins number **14** and **15** should be approximately 110 Ohms at the room temperature (20 °C).

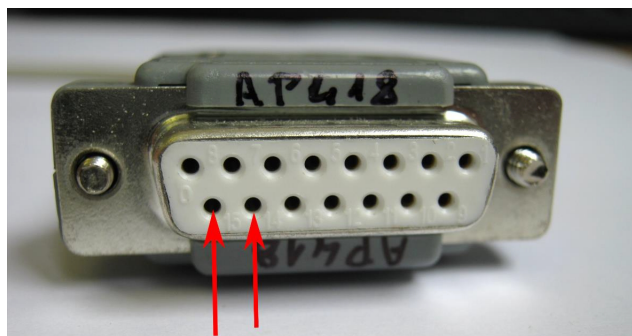

Figure 12: Measuring pins of CS4 temperature sensor

4.6 Furnace Testing

One of the reasons of **CS Open Heating** error is the broken heating wire inside furnace. To check the conductivity of this wire perform following procedure.

- Unscrew two screws marked on the Fig.13 and remove the cable holder.
- Loosen the two screws marked on the Fig.14 and remove the cables from the furnace.

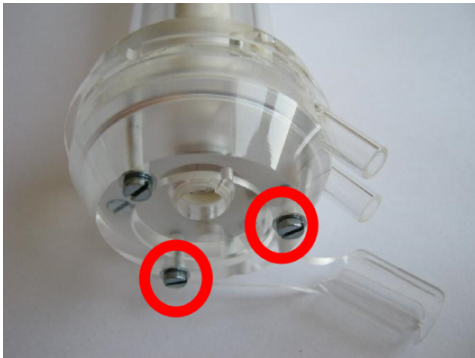

Figure 13: Screws holding cable holder



Figure 14: Screws fixing cables

- Measure the resistivity as shown on fig.15, value should be close to 4 Ohms. If the value is infinity, then heating wire inside the furnace is broken.



Figure 15: Resistivity measurement

5 Maintenance

5.1 Cleaning the Temperature Sensor and Measuring Vessel

5.1.1 Measuring Vessel Cleaning

The specimen silica glass vessel should be cleaned regularly to achieve the right results.

- Ultrasonic cleaning is a very effective and a very quick procedure for the cleaning of the measuring vessels.
- Cotton-wool wound on a skewer is used for the mechanical cleaning of the specimen vessel interior. Cotton-wool can be soaked with various solvents (e.g. acetone, ethanol).
- Chemical cleaning is needed if a specimen was smelted during measurement. Contact a chemist for rules for manipulation with acids before using the following procedure. Be careful while operating with acids. Recommended acids are **HCl** – Hydrochloric acid and **H₂SO₄** – Sulfuric acid.
 - put the acid in a cylindrical vessel made from laboratory glass
 - put the acid in the specimen vessel
 - insert the specimen vessel into the acid
 - let the acid act for several hours
 - exchange the acid several times
 - pour the acid out
 - rinse the specimen vessel with clean water several times
 - dry the vessel carefully

5.1.2 Temperature Sensor Cleaning

Temperature sensor should be carefully cleaned after each specimen measurement. For the cleaning use cotton-wool, which can be soaked with various solvents (e.g. acetone, ethanol), if necessary. After cleaning dry up the sensor.



Do not use ultrasonic cleaning for thermometer. Take care of outlet wires of the thermometer as well. In any manipulations, do not bend them too much.

6 Appendix

6.1 EC Declaration of Conformity

We,

AGICO, s.r.o., Ječná 29a, CZ - 621 00 Brno, IČO 607 313 54,

declare that the product:

Modulus Type:	CS4	indicator of temperature variation of susceptibility from room temperature to 700 °C,
Modulus Type:	CSL	indicator of temperature variation of susceptibility from -192 °C to room temperature,
Manufacturer:	AGICO, s.r.o., Ječná 29a, CZ - 621 00 Brno, IČO 607 313 54	
Place of production:	AGICO, s.r.o., Ječná 29a, CZ - 621 00 Brno, IČO 607 313 54	

fulfils the applicable requirements of following regulations / normative documents and technical specifications:

	Regulation used	As Czech implementation of
1	ČSN EN 55022 class B	EN 55022:1998, ČSN EN 55022:1999 + A1:2001 + A2:2001 + Z2:2001
2	ČSN EN 61326-1 for basic requirements	EN 61326-1:2006, ČSN EN 61326-1:2006
3	ČSN EN 61000-4-2 criterion B	EN 61000-4-2:1995 + A1:1998, ČSN EN 61000-4-2:1997 + A1:1999
4	ČSN EN 61000-4-3 criterion A	EN 61000-4-3:2006, ČSN EN 61000-4-3 ed.3:2006
5	ČSN EN 61000-4-4 criterion B	EN 61000-4-4:2004, ČSN EN 61000-4-4 ed.2:2005
6	ČSN EN 61000-4-5 criterion B	EN 61000-4-5:2006, ČSN EN 61000-4-5 ed.2:2007
7	ČSN EN 61000-4-6 criterion A	EN 61000-4-6:1996 + A1:2001, ČSN EN 61000-4-6:1997 + Z1:2001
8	ČSN EN 61000-4-11	EN 61000-4-11:2004, ČSN EN 61000-4-11 ed.2:2005

Responsible person: Bc. Petr Pokorný, development engineer

6.2 Warranty

AGICO warrants that this product will be free from defects in materials and workmanship for a period of usually 1 (one) year from date of installation. However, if the installation is performed later than 3 (three) months after the date of shipment due to causes on side of the Customer, the warranty period begins three months after the date of shipment. If any such product proves defective during this warranty period, AGICO, at its option, either will repair the defective product without charge for parts and labor, or will provide a replacement in exchange for the defective product.

In order to obtain service under this warranty, Customer must notify AGICO of the defect before the expiration of the warranty period and make suitable arrangements for the performance of service. AGICO will decide if the repair is to be performed by AGICO technician or AGICO delegated serviceman in customers laboratory, or product shall be sent for repair to the manufacturer. In latter case, customer shall be responsible for packaging and shipping the defective product to the AGICO service centre. In both cases, all the costs related to a warranty repair shall be at expenses of AGICO.

The warranty becomes invalid if the Customer modifies the instrument or fails to follow the operating instructions, in case of failure caused by improper use or improper or inadequate maintenance and care, or if the Customer attempts to install the instrument without explicit written permission of AGICO company. AGICO shall not be obligated to furnish service under this warranty

- to repair damage resulting from attempts by personnel other than AGICO representatives to install, repair or service the product;
- to repair damage resulting from improper use or connection to incompatible equipment; or
- to service a product that has been modified or integrated with other products when the effect of such modification increases the time or difficulty of servicing the product.

This warranty is given by AGICO with respect to this product in lieu of any other warranties, expressed or implied. AGICO and its vendors disclaim any implied warranties of merchantability or fitness for a particular purpose. AGICO's responsibility to repair or replace defective products is the sole and exclusive remedy provided to the Customer for breach of this warranty. AGICO and its vendors will not be liable for any indirect, special, incidental, or consequential damages irrespective of whether AGICO or vendor has advance notice of the possibility of such damages.